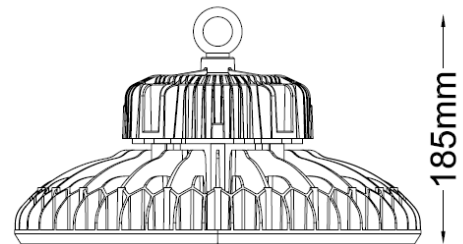
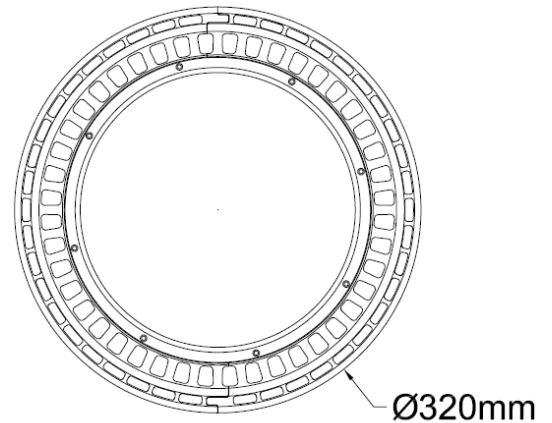

NAME: LUXUMSATURN**P/N: LXHB02100W**

Superior high quality Led High Bay lights are suitable for mounting at height with many applications such as Warehouse. Factory and workshops. Agricultural buildings. Exhibition halls.

Advantage:

- CE RoHS SAA certificate
- Mean Well IP65 driver, Input voltage 100-240Vac
- No UV or IR in the beam
- Easy to install and operate
- Energy saving, long lifespan
- Instant start, NO flickering, NO humming
- Green and eco-friendly without mercury
- Output constant current level can be adjusted through output cable with 1-10V, PWM signal and Resistance.

**Application: (typical)**

- ◆ Warehouse, factory and workshops;
- ◆ Agricultural buildings;
- ◆ Exhibition hall;
- ◆ Gymnasium and supermarkets, etc.

Product Specifications

Product name	LUXUMSATURN
Product No	LXHB02100W
Dimension	∅ 320 x 185 mm

Technical Characteristic

Color temperature	6000K
CRI	>80
Lumen	14000LM -Max
Input Power	100W
Viewing Angle	120°
Input Voltage	100-240Vac 50/60Hz
Driver model	HBG-100-60B (Mean Well Driver)
PFC	>0.9
Waterproof Rating	IP65

Materials

LED Brand	PHILIPS LUMILEDS
LED Type	LUXEON 3030 2D (1.5W)
LED QTY	153 PCS
Housing	Aluminum
Housing color	Black
Cover	Polycarbonate

Others

Operating Temperature	-20deg <>45deg
Operating Humidity	20%-90% RH
Storage Temperature	-30deg ><80deg
Storage Humidity	10%-95%
Application	Indoor / Outdoor
Safety Certification	CE RoHS SAA
Warranty	5 Years

Light Distribution Testing Parameters

DATA OF LAMP		PHOTOMETRIC DATA Eff: 132.66 lm/W			
MODEL		I _{max} (cd)	4373	S/MH (C0/180)	1.31
NOMINAL POWER (W)	100	LOR (%)	100.0	S/MH (C90/270)	1.27
RATED VOLTAGE (V)	240	TOTAL FLUX (lm)	12388	η UP, DN (C0-180)	0.0, 52.1
NOMINAL FLUX (lm)	12387.8	CIE CLASS	DIRECT	η UP, DN (C180-360)	0.0, 47.9
LAMPS INSIDE	1	η up (%)	0.0	CIBSE SHR NOM	1.25
TEST VOLTAGE (V)	240	η down (%)	100.0	CIBSE SHR MAX	1.35

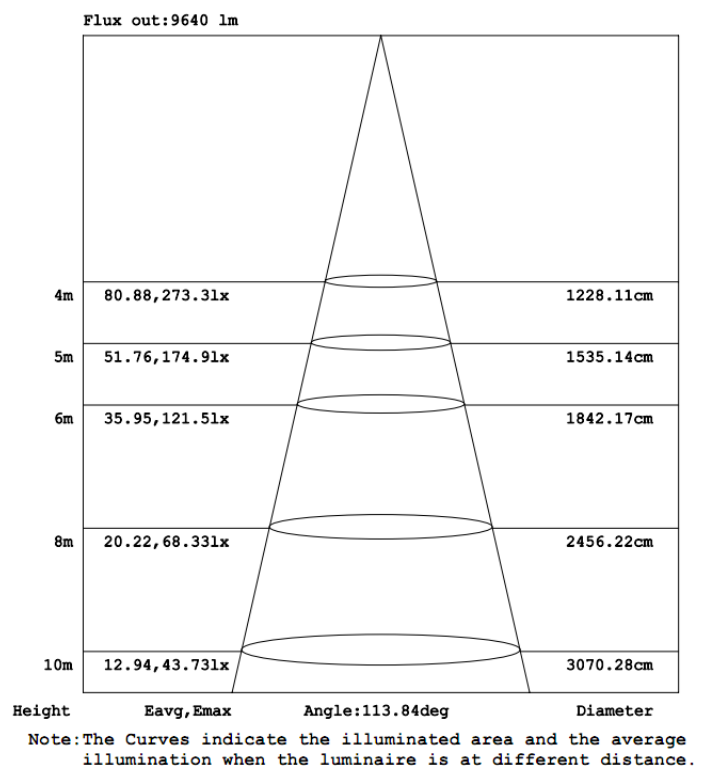
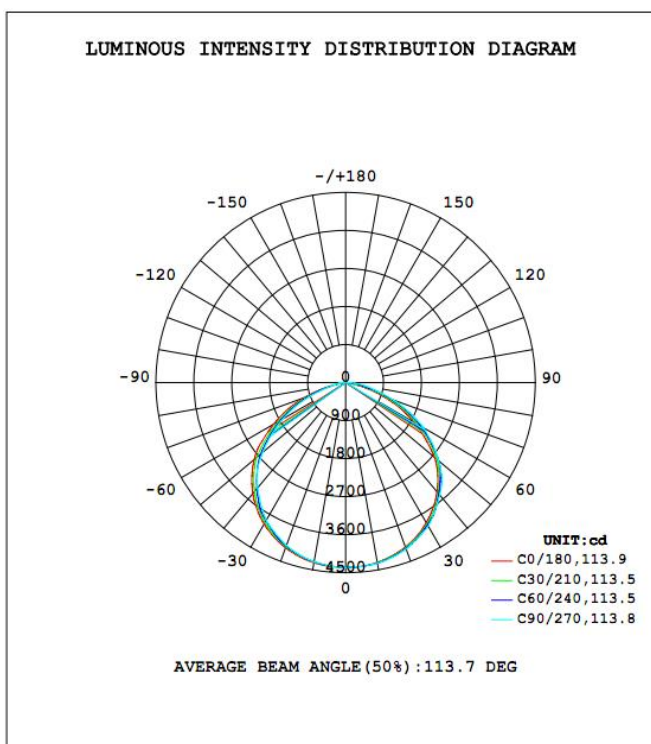

This lamp has been tested to IESNA LM-79-08, "Electrical and Photometric Measurements of Solid-State Lighting Products".

This lamp passes the eligibility criteria for the Energy Technology List (ETL) - Efficient White Lighting Units.

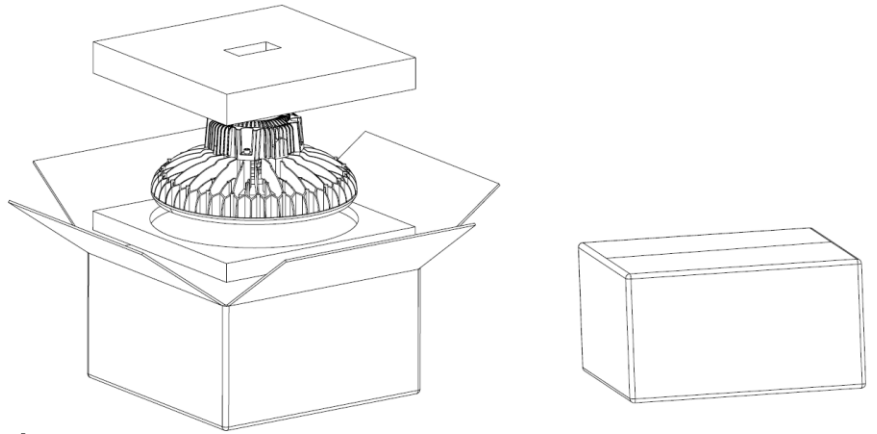

This product is certified and marked.

**Package****Lamps Net Weight: 4.9 kg / pc**

	Size	Qty/Carton	Weight/Carton
Outer box	370 x 370 x 200 mm	1	5.9 kg