

NAME: SATURN SENSOR 200W

P/N: LXSR5200W



The Saturn Sensor is a high quality Led High Bay - Low Bay light with an in built motion sensor, suitable for mounting at various heights with many application uses such as Warehouse, Factory, Workshops, Agricultural Buildings and Exhibition Halls to name a few.

This Light is ideal to replace traditional high wattage lighting, also the perfect selection for new installations. High energy saving using Sensor detection.

The Saturn Sensor high bay is equipped with the high quality HongLi 2835 chip driven by the renowned Sosen driver giving surety of quality at an affordable price. This lamp is also dimmable.

Advantage:

- CE RoHS SAA certificate
- No UV or IR in the beam
- Easy to install and operate
- Motion sensor
- Energy saving, long lifespan
- Instant start, NO flickering, NO humming
- Green and eco-friendly without mercury
- Output constant current level can be adjusted through output cable with 1-10V, PWM signal and Resistance.

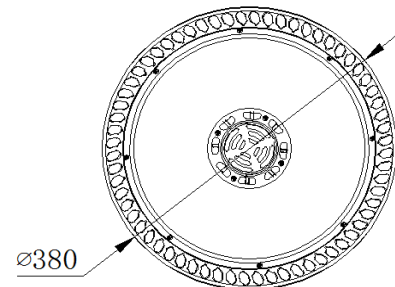
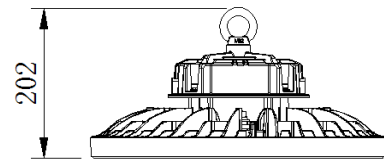

Application: (typical)

- ◆ Warehouse, factory and workshops;
- ◆ Agricultural buildings;
- ◆ Exhibition hall;
- ◆ Gymnasium and supermarkets.

Product Specifications

Product name	SATURN SENSOR 200W
Product No	LXSR5200W
Dimension	∅ 380 x 220 mm

Technical Characteristic

Color temperature	6000K
CRI	>80
Lumen	28,000lm-Max
Input Power	200W
Viewing Angle	110°
Input Voltage	100-240Vac 50/60Hz
Driver model	Sosen
PFC	>0.9
LOR	99%
Waterproof Rating	IP65

Materials

LED Brand	HongLi
LED Type	HongLi 2835
LED QTY	630 PCS
Housing	Aluminum
Housing color	Black
Lens	Tempered Glass

Others

Operating Temperature	-20deg <>50deg
Operating Humidity	20%-90% RH
Storage Temperature	-30deg ><80deg
Storage Humidity	10%-95%
Application	Indoor / Outdoor
Safety Certification	CE, RoHS
Warranty	5 Years manufacture warranty

Light Distribution Testing Parameters

DATA OF LAMP		PHOTOMETRIC DATA Eff: 141.21 lm/W			
MODEL		I _{max} (cd)	9943	S/MH (C0/180)	1.30
NOMINAL POWER (W)	200	LOR (%)	100.0	S/MH (C90/270)	1.29
RATED VOLTAGE (V)	120	TOTAL FLUX (lm)	28153	η UP, DN (C0-180)	0.0, 49.6
NOMINAL FLUX (lm)	28153	CIE CLASS	DIRECT	η UP, DN (C180-360)	0.0, 50.4
LAMPS INSIDE	1	η up (%)	0.0	CIBSE SHR NOM	1.25
TEST VOLTAGE (V)	120	η down (%)	100.0	CIBSE SHR MAX	1.35

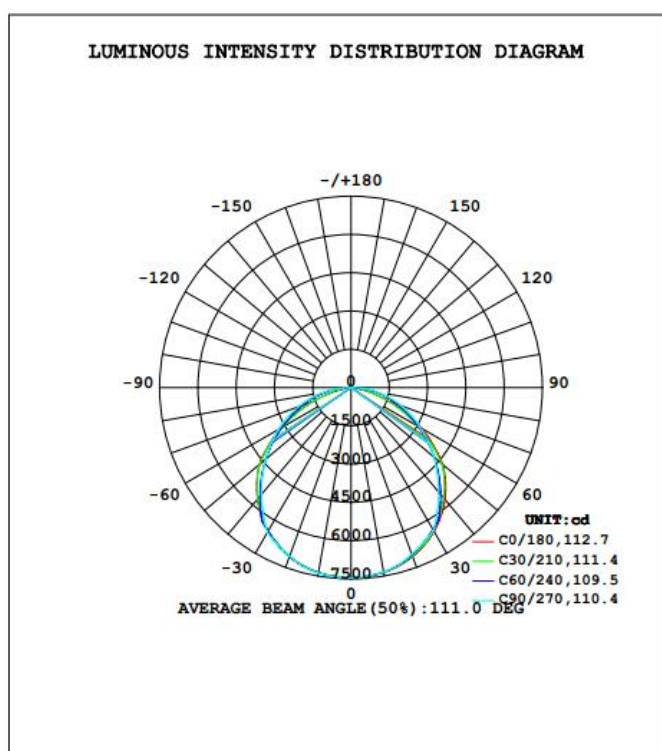

Flux out: 10310 lm

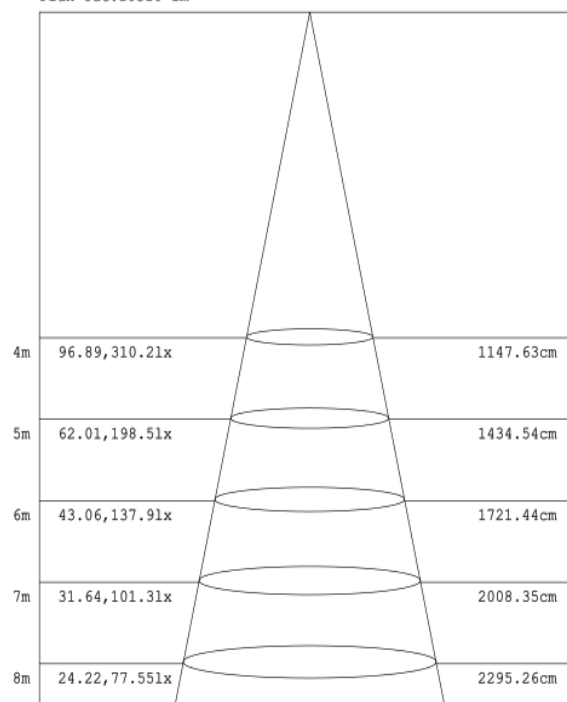

Note: The Curves indicate the illuminated area and the average illumination when the luminaire is at different distance.

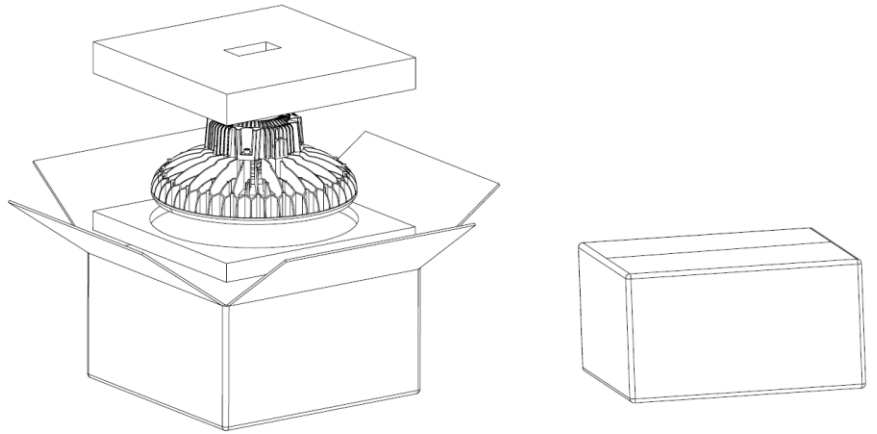

This product is certified and marked.

**Package****Lamps Net Weight: 5.0 kg**

	Size	Qty/Carton	Weight/Carton
Outer box	442 x 442 x 206 mm	1	6.1 kg