

NAME:Luxum Series2 Saturn - 150W

P/N:LXS2R150W



Superior high quality Led High Bay lights are suitable for mounting at height with many applications such as Warehouse. Factory and workshops. Agricultural buildings. Exhibition halls.

**Advantage:**

- CE RoHS SAA certificate
- No UV or IR in the beam
- Easy to install and operate
- Energy saving, long lifespan
- Instant start, NO flickering, NO humming
- Green and eco-friendly without mercury
- Output constant current level can be adjusted through output cable with 1-10V, PWM signal and Resistance.

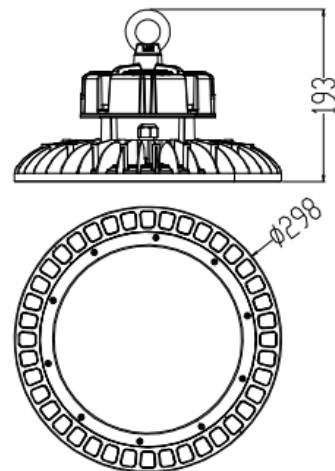
**Application: (typical)**

- ◆ Warehouse, factory and workshops;
- ◆ Agricultural buildings;
- ◆ Exhibition hall;
- ◆ Gymnasium and supermarkets.

**Product Specifications**

Product name	Luxum Series2 Saturn - 150W
Product No	LXS2R150W
Dimension	∅ 298 x 193 mm

**Technical Characteristic**

Color temperature	6000K
CRI	>80
Lumen	21750LM -Max
Input Power	150W
Viewing Angle	120°
Input Voltage	100-240Vac 50/60Hz
Driver model	Sosen
PFC	>0.9
LOR	99%
Waterproof Rating	IP65

**Materials**

LED Brand	HongLi
LED Type	HongLi 2835
LED QTY	375 PCS
Housing	Aluminum
Housing color	Black
Lens	Polycarbonate

**Others**

Operating Temperature	-20deg <>45deg
Operating Humidity	20%-90% RH
Storage Temperature	-30deg ><80deg
Storage Humidity	10%-95%
Application	Indoor / Outdoor
Safety Certification	CE, RoHS
Warranty	5 Years

## Luminaire Property

Luminaire Manufacturer:  
Voltage: 120.6 V  
Power: 150.80 W

Current: 1.260 A  
Power Factor: 0.992

## Photometric Results

CIE Class: Direct  
Measurement Flux: 19616.2 lm  
Downward Ratio: 99%  
Horizontal Diffuse Angle(50%): H114.9  
Vertical Diffuse Angle(50%): V114.9  
Luminaire Efficacy Rating (LER): 130.13  
Max. Intensity: 6952.9 cd  
S/MH(C0/C180): 1.29

Total Rated Lamp Lumens: 19616.2 lm  
Efficiency: 100%  
Upward Ratio: 1%

Central Intensity: 6952.89 cd  
Pos of Max. Intensity: H0 V0  
S/MH(C90/C270): 1.29

Luminous Intensity Distribution Curve

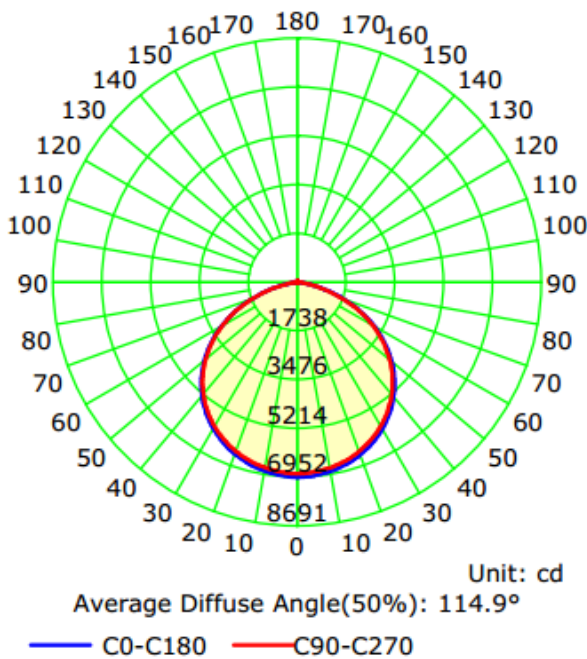

The Average Illuminance Effective Figure

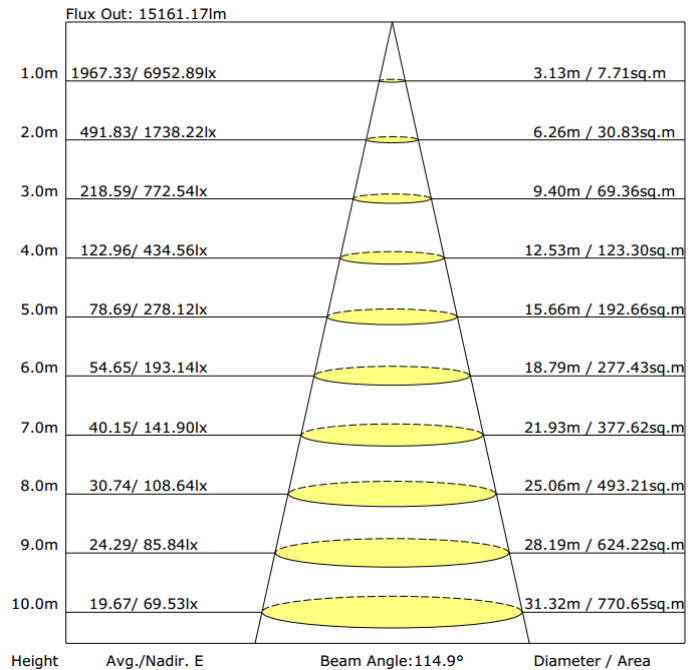

This lamp has been tested to IESNA LM-79-08, "Electrical and Photometric Measurements of Solid-State Lighting Products".

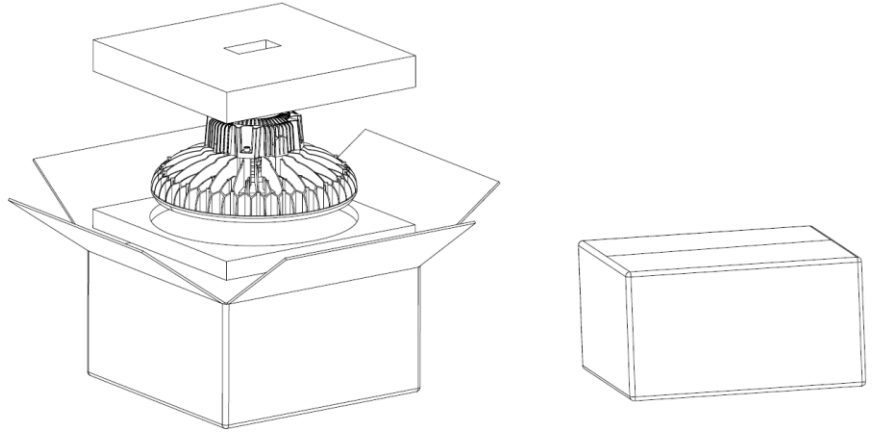

This product is certified and marked.

**Package****Lamps Net Weight: 3.7 kg**

	Size	Qty/Carton	Weight/Carton
Outer box	352 x 352 x 196 mm	1	4.7 kg