

NAME: LUXUM SATURN SERIES 2 - 200W

P/N: LXSQ6200W



Superior high quality Led High Bay lights are suitable for mounting at height with many applications such as Warehouse. Factory and workshops. Agricultural buildings. Exhibition halls.

Advantage:

- CE RoHS SAA certificate
- No UV or IR in the beam
- Easy to install and operate
- Energy saving, long lifespan
- Instant start, NO flickering, NO humming
- Green and eco-friendly without mercury
- Output constant current level can be adjusted through output cable with 1-10V, PWM signal and Resistance.

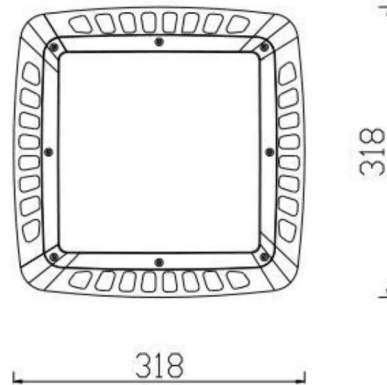
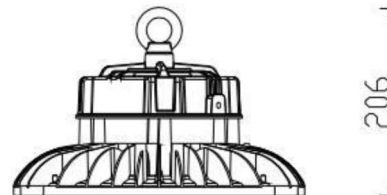
**Application: (typical)**

- ◆ Warehouse, factory and workshops;
- ◆ Agricultural buildings;
- ◆ Exhibition hall;
- ◆ Gymnasium and supermarkets.

Product Specifications

Product name	LUXUM SATURN SERIES 2 - 200W
Product No	LXSQ6200W
Dimension	318 x 206 mm

Technical Characteristic

Color temperature	6000K
CRI	>80
Lumen	29000LM-Max
Input Power	200W
Viewing Angle	110°
Input Voltage	100-240Vac 50/60Hz
Driver model	Sosen
PFC	>0.9
LOR	99%
Waterproof Rating	IP65

Materials

LED BRAND	Philips
LED TYPE	Lumileds
LED QTY	512 PCS
Housing	Aluminum
Housing color	Black
Lens	Polycarbonate

Others

Operating Temperature	-20deg <>45deg
Operating Humidity	20%-90% RH
Storage Temperature	-30deg ><80deg
Storage Humidity	10%-95%
Application	Indoor / Outdoor
Safety Certification	CE, RoHS
Warranty	5 Years

Luminaire Property

Luminaire Manufacturer:
Voltage: 120.3 V
Power: 203.30 W

Current: 1.703 A
Power Factor: 0.993

Photometric Results

IES Classification: Type II
Total Rated Lamp Lumens: 26445.7 lm
Efficiency: 100%
Upward Ratio: 1%
Central Intensity: 9442.63 cd
Pos of Max. Intensity: H0 V0

Longitudinal Classification: Very Short
Measurement Flux: 26445.7 lm
Downward Ratio: 99%
Luminaire Efficacy Rating (LER): 130.13
Max. Intensity: 9442.63 cd

Luminous Intensity Distribution Curve

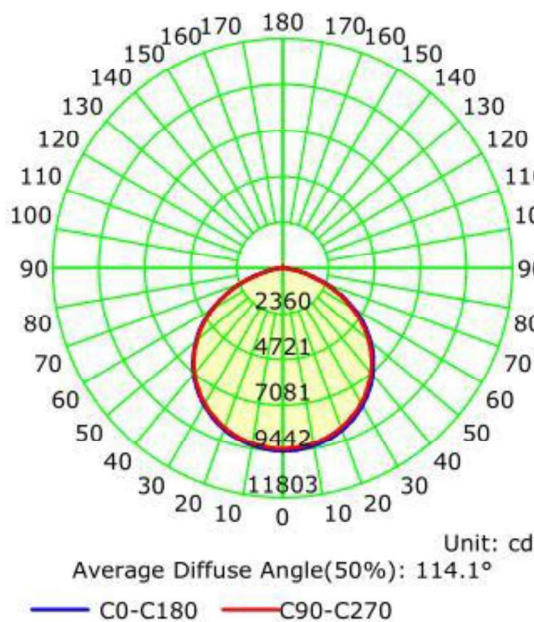

The Average Illuminance Effective Figure

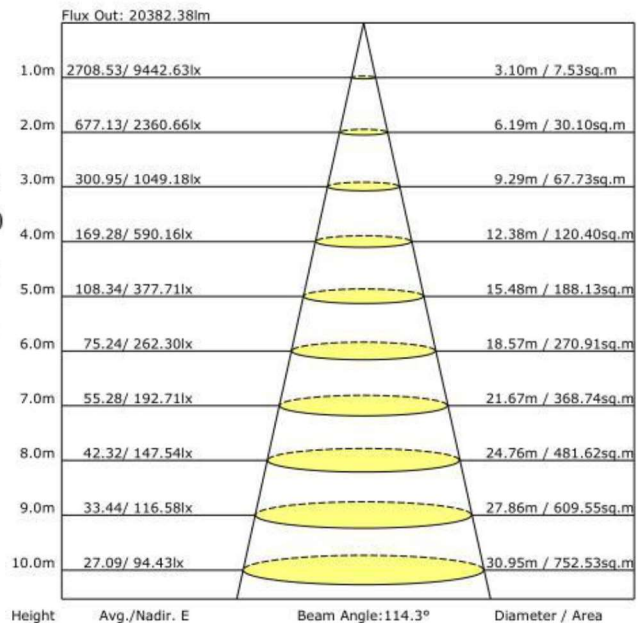

This lamp has been tested to IESNA LM-79-08, “Electrical and Photometric Measurements of Solid-State Lighting Products”.

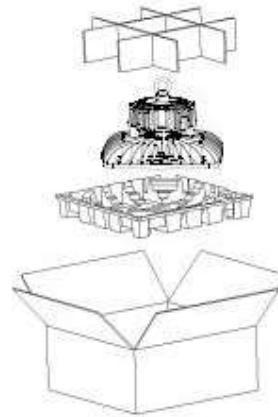

This product is certified and marked

**Package****Lamps Net Weight: 3.6 kg**

	Size	Qty/Carton	Weight/Carton
Outer box	375 x 375 x 190 mm	1	4.3 kg